

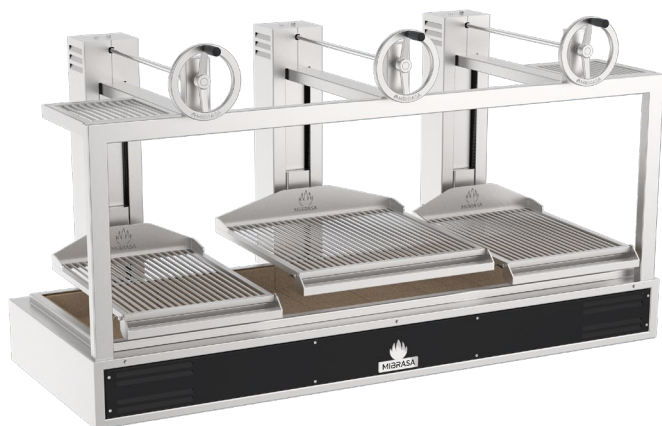

TRIPLE 200

Mibrasa® Parrilla with three grills

TECHNICAL INFORMATION



Reference	GMB200-3GR
Fire up time*	30 min
Cooking temperature	250 °C
Grill height range	350 mm
Initial charcoal load ¹	20 kg
Charcoal load duration ²	5 h
Equivalent power*	6 kW
Exhaust rate	5100 m ³ /h
Net weight ³	515 kg
Crated weight ³	685 kg
Crate dimensions (WxDxH)	1120 x 2200 x 1380 mm

*Approximate data

1. Consult instruction manual

2. Will vary depending on quality of charcoal

3. Weight with accessories included

FEATURES

Precision and strength is key to the PARRILLA MIBRASA®. Effortlessly regulate the height of your grill surface thanks to the carefully engineered double chain system coupled with the crank wheel and gearbox, keeping maintenance down to a minimum.

The system lets us sear, cook and rest our ingredients, to get the optimal result every time.

ERGONOMICALLY DESIGNED WITH MAXIMUM QUALITY AND SECURITY

With a sloping grill, the grease runs down the weld-free grill bars to prevent grease build-up. Grease drips down to the collector with an easy to remove mechanism ready to clean.

The base is lined with refractory bricks to ensure maximum heat efficiency and resistance to pure fire. And the built-in cooling system in outer case guarantees a maximum level of security.

Built using quality steels providing strength and durability; ergonomically designed for practicality and ease of use, each feature plays a crucial part in delivering the ultimate grilling machine for every chef.

INCLUDED ACCESSORIES

- Mibrasa tongs [TG]
- Ash shovel [PALA]
- Ember poker [PK]
- Grill brush [CEP]
- 2 rod grills [CPV-160F], 1 rod grill [CPV-160]

OPTIONAL ACCESSORIES

- V-shape grill [GV-160F], GV-160]
- End of service lid [TAPA65]
- Protective structure [EPGMB200F]
- Espeto kit [KITESPGMB200]
- Gastronorm kit [SGN200]

Color



Edition



Gold Black Copper Titanium Silver

QUALITY GUARANTEE



Rev. 9/23

Mibrasa® Charcoal Ovens S.L

C/Joan Rovira i Bastons, 26

17230 Palamós - Spain

+34 972 601 942 - mibrasa@mibrasa.com

www.mibrasa.com

Front view

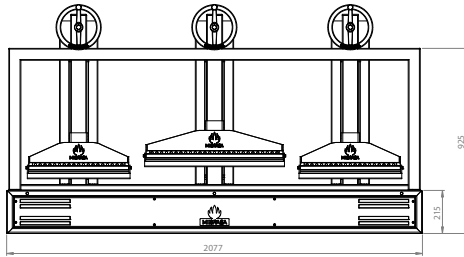

Side view

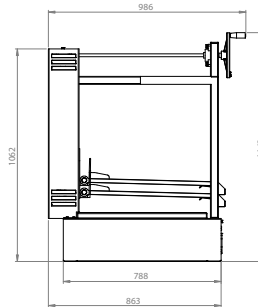

Top view

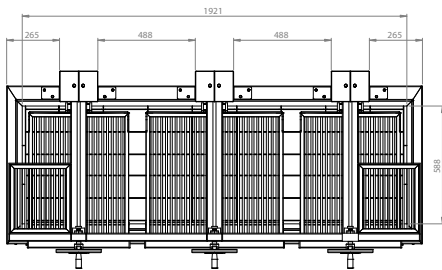

Dimensions in mm

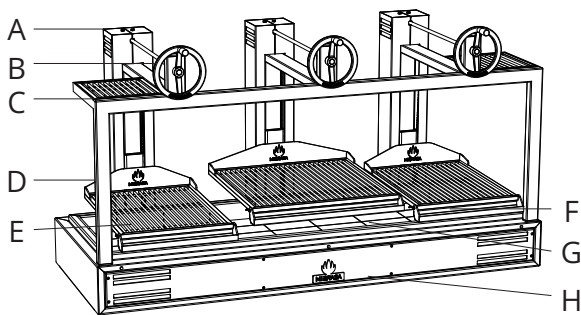

A	Elevating system
B	Elevating wheel
C	Heating rack
D	Structure
E	Grill
F	Grease collector
G	Refractory bricks
H	Main body

GRILL TYPES

Rod bar grill

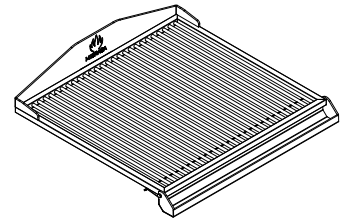

V shape grill

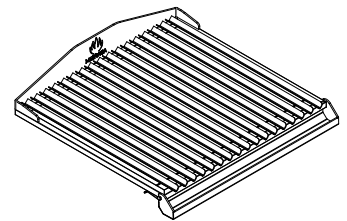

GRILL DIMENSIONS

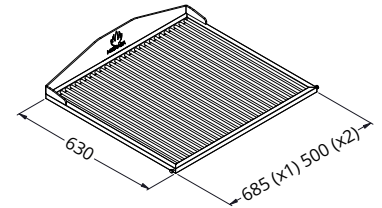

DIMENSIONES DEL SOPORTE BANDEJA

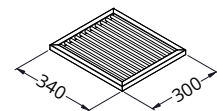

INSTALLATION GUIDELINES AND SAFETY STANDARDS

Recommended installation height	700 mm
Clearances to construction/other appliances from the Parrilla	76 mm
Clearances of flammable materials from the Parrilla	300 mm
Clearance of workspace from front of the Parrilla	700 mm



It is recommended to use a lifting device to lift the Parrilla and place on the countertop/stand. Consult Parrilla instruction manual for further information.

Specifications and design are subject to change without notice.

OPTIONAL COMPLETE STAND



TECHNICAL INFORMATION

Ref.	GMB200-3GR + MCGMB200
Net weight ³	640 kg
Crated weight ³	785 kg
Crate dimensions (WxDxH)	1120 x 2200 x 2000mm

Ref.	MCGMB200
Net weight ³	125 kg
Crated weight ³	270 kg
Crate dimensions (WxDxH)	1120 x 2200 x 700mm

OPTIONAL ACCESSORIES

- Stainless steel casters [WINOXG]

Dimensions in mm

FRONT VIEW

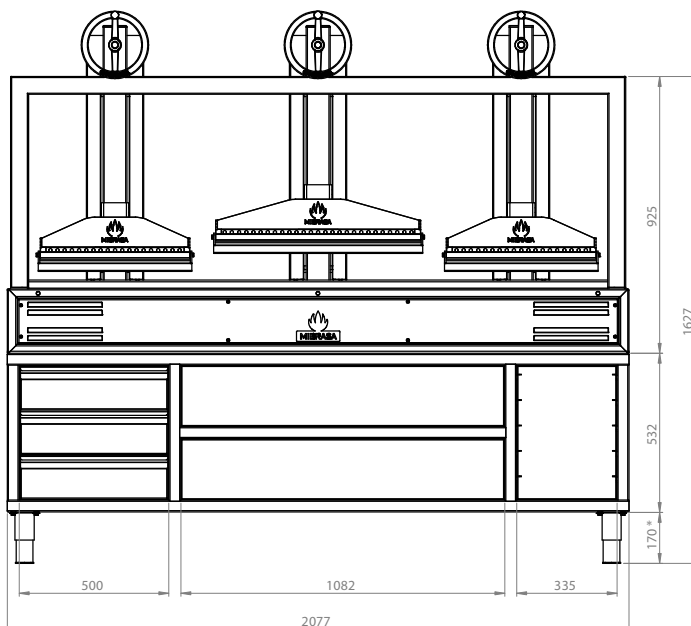

SIDE VIEW

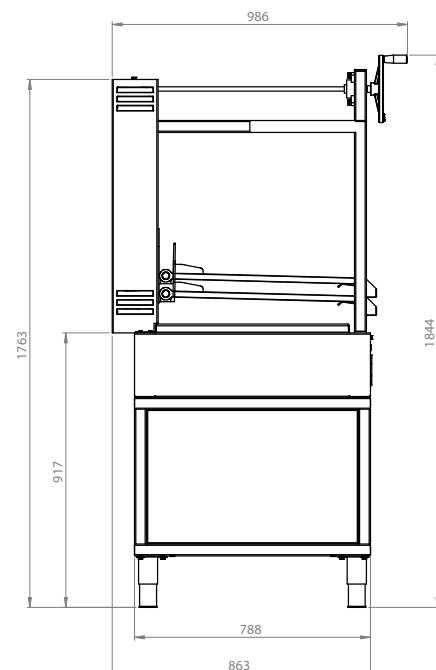

*Adjustable leg height 135-195 mm

OPTIONAL STAND



TECHNICAL INFORMATION

Ref.	GMB200-3GR + MGMB200
Net weight ³	562 kg
Crated weight ³	629 kg
Crate dimensions (WxDxH)	1120 x 2200 x 2000 mm

Ref.	MGMB200
Net weight ³	47 kg
Crated weight ³	114 kg
Crate dimensions (WxDxH)	1120 x 2200 x 700 mm

OPTIONAL ACCESSORIES

- Stainless steel casters [WINOXG]

Dimensions in mm

FRONT VIEW

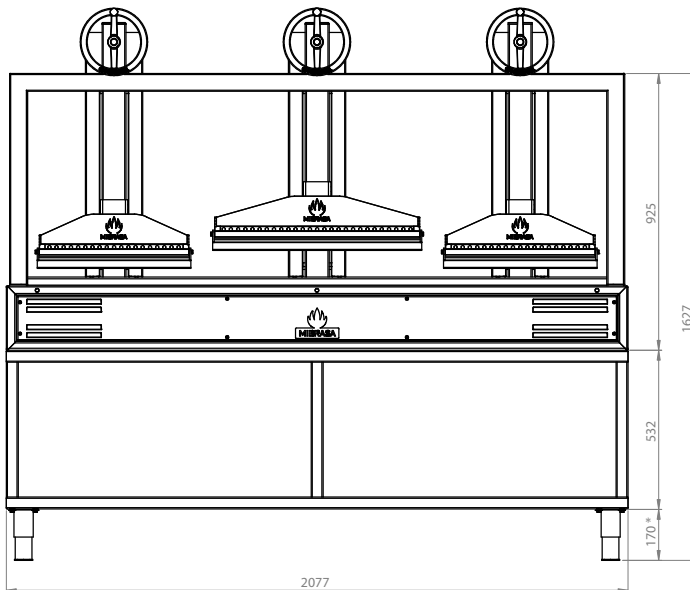

SIDE VIEW

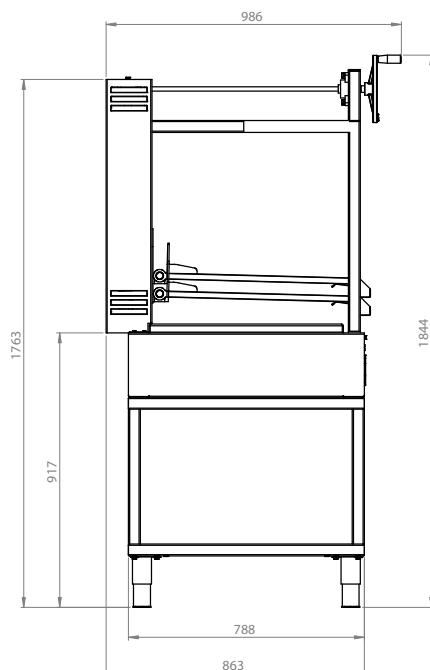

*Adjustable leg height 135-195 mm