



# DUO

# SINGLE + COMPACT-S

Parrilla Single + Mibrasa Oven



## FEATURES

The Mibrasa DUO is an integral solution for restaurants that want to maximize their cooking production with the best possible execution and result.

In one sole unit, the DUO is made up of two Mibrasa grilling machines: Charcoal oven and Parrilla; a synergy that guarantees chefs absolute control through an agile workspace that in turn speeds up cooking processes.

Each Mibrasa grilling machine features unique characteristics that enable different cooking processes. This combination allows us to work with all simultaneously and as a result maximizes the capacity for creation.

Ref. DUOGMB100\_HMB75

## INCLUDED ACCESSORIES

### Oven Compact-S (HMB 75)

- Grill/s [GT75]
- Firebreak-dissipating filter [FB-DF]
- Mibrasa tongs [TG]
- Grill brush [CEP]
- Ash shovel [PALA]
- Poker [PK75]

### Parrilla Single (GMB 100)

- Rod grill [CPV-100\_200]
- Ember [PK]
- Mibrasa tongs [TG]
- Grill brush [CEP]
- Ash shovel [PALA]

| TECHNICAL INFORMATION               | Parrilla Single (GMB 100) | Oven Compact-S (HMB 75) |
|-------------------------------------|---------------------------|-------------------------|
| Fire up time*                       | 30 min-average            | 45 min-average          |
| Cooking temperature                 | 250 °C                    | 250 - 350 °C            |
| Covers per service*                 | NA                        | 75 - 95                 |
| Cooking surface area                | 890 x 630 mm              | 540 x 395 mm            |
| Grill height range                  | 350 mm                    | NA                      |
| Initial charcoal load <sup>1</sup>  | 10 kg                     | 10 kg                   |
| Charcoal load duration <sup>2</sup> | 5 h                       | 8 h                     |
| Equivalent power*                   | 4,5 kW                    | 3,5 kW                  |
| Exhaust rate                        | 4100 m3/h                 | 2800 m3/h               |
| Net weight                          | 708 kg                    |                         |
| Crated weight                       | 889 kg                    |                         |
| Crated dimensions (WxDxH)           | 2010 x 1060 x 2000 mm     |                         |

\*Approximate data 1. Consult instruction manual 2. Will vary depending on quality of charcoal

## SURFACE DIMENSIONS

Oven grill (x2)

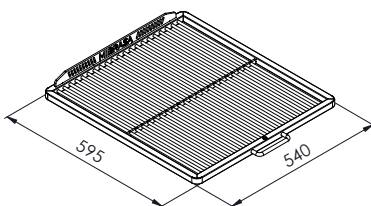

Parrilla grill

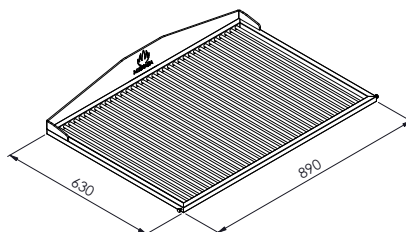

Parrilla heating rack (x2)

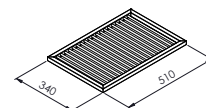

QUALITY GUARANTEE



Rev. 9/23

Mibrasa® Charcoal Ovens S.L

C/Joan Rovira i Bastons, 26

17230 Palamós - Spain

+34 972 601 942 - mibrasa@mibrasa.com

www.mibrasa.com

Front view

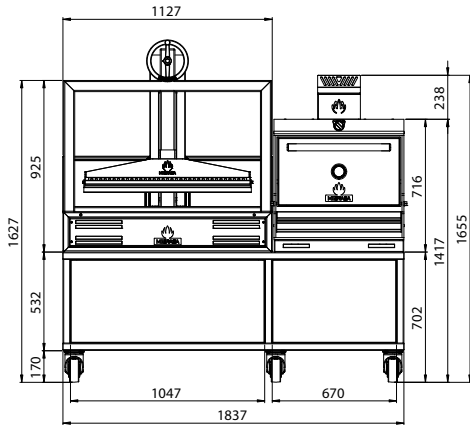

Side view

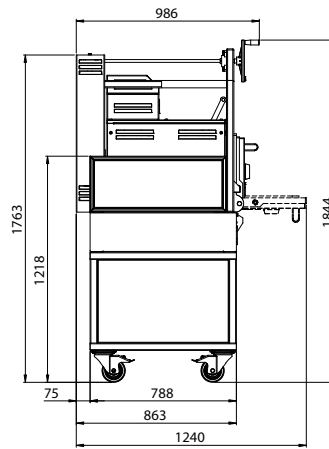

Top view

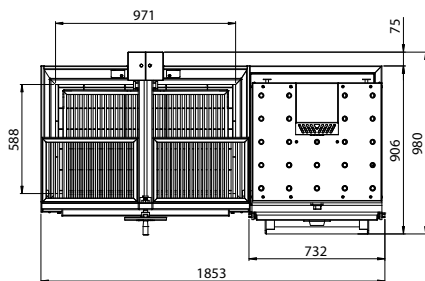

Dimensions in mm

Revit drawings available on request at [mibrasa@mibrasa.com](mailto:mibrasa@mibrasa.com)

### CUSTOMIZATION

#### COLOR



BLACK



RED



BLUE



YELLOW



STAINLESS  
STEEL

#### EDITION



GOLD



BLACK



COPPER



TITANIUM



SILVER



WOOD

The Edition finishes are applied to the logos, crank wheel, door handle and the thermometer casing.

\*Only on the door handle (logos and thermometer casing in silver)

| PARRILLA MIBRASA |                      |
|------------------|----------------------|
| A                | Elevating system     |
| B                | Elevating wheel      |
| C                | Heating rack         |
| D                | Structure            |
| E                | Protective structure |
| F                | Grill                |
| G                | Grease collector     |
| H                | Refractory bricks    |
| I                | Main body            |
| J                | Stand                |
| K                | Swivel casters       |

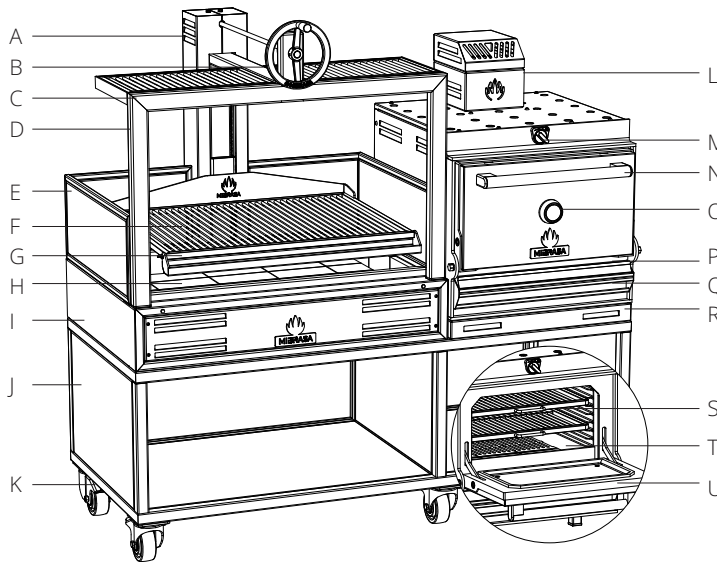

| OVEN MIBRASA |                              |
|--------------|------------------------------|
| L            | Firebreak-dissipating filter |
| M            | Regulador tiro superior      |
| N            | Upper damper                 |
| O            | Thermometer                  |
| P            | Removable grease collector   |
| Q            | Lower damper/ash collector   |
| R            | Trim base worktop            |
| S            | Grills                       |
| T            | Charcoal grids               |
| U            | Door                         |

### SAFETY STANDARDS AND INSTALLATION GUIDELINES

|  |         |
|--|---------|
| Clearances to construction/other appliances from the DUO | 76 mm   |
| Clearances of flammable materials from the DUO           | 300 mm  |
| Clearance of workspace from front of the DUO             | 1100 mm |

Specifications and design are subject to change without notice.