



DUO BEAST + COMPACT S

Robata Beast with Mibrasa Oven



FEATURES

The Mibrasa DUO is an integral solution for restaurants that want to maximize their cooking production with the best possible execution and result.

In one sole unit, the DUO is made up of two Mibrasa grilling machines: Charcoal oven and Robata Beast; a synergy that guarantees chefs absolute control through an agile workspace that in turn speeds up cooking processes.

Each Mibrasa grilling machine features unique characteristics that enable different cooking processes. This combination allows us to work with all simultaneously and as a result maximizes the capacity for creation.

Ref. DUORM100_HMB75

INCLUDED ACCESSORIES

OVEN COMPACT HMB 75

- 2 grills [GT75]
- Firebreak-dissipating filter [FB-DF]
- Mibrasa tongs [TG]
- Grill brush [CEP]
- Ash shovel [PALA]
- Poker [PK75]

ROBATA BEAST RM 100

- 6 top and lower grills [RLTG100]
- 6 middle grills [RMG100]
- Poker [PK]
- Mibrasa tongs [TG]
- Grill brush [CEP]
- Ash shovel [PALA]

TECHNICAL INFORMATION	RM 100	HMB 75
Fire up time*	30 min-average	45 min-average
Cooking temperature	250 °C	250 - 350 °C
Covers per service*	NA	75 - 95
Cooking surface area	6x (384 x 316 mm) 6x (653 x 316 mm)	540 x 395 mm
Initial charcoal load ¹	10 kg	10 kg
Charcoal load duration ²	5 h	7 h
Equivalent power*	4.5 kW	3.5 kW
Exhaust rate	2800 m ³ /h	2800 m ³ /h
Net weight	661 kg	
Crated weight	842 kg	
Crated dimensions	2010 x 970 x 1870 mm	

*Approximate data 1. Consult instruction manual 2. Will vary depending on quality of charcoal

SURFACE DIMENSIONS

Oven grill (x2)

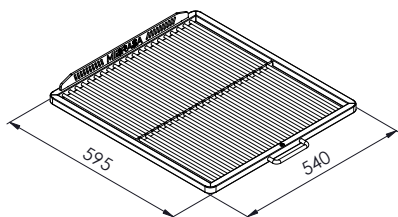

Robata Beast grills
Top and bottom (x6)

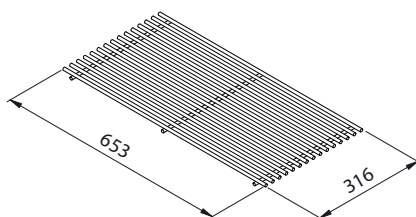

Middle (x6)

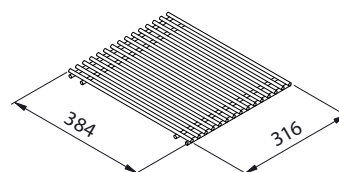

QUALITY GUARANTEE



Rev. 9/23

Mibrasa® Charcoal Ovens S.L
C/Joan Rovira i Bastons, 26
17230 Palamós - Spain
+34 972 601 942 - mibrasa@mibrasa.com
www.mibrasa.com

Front view

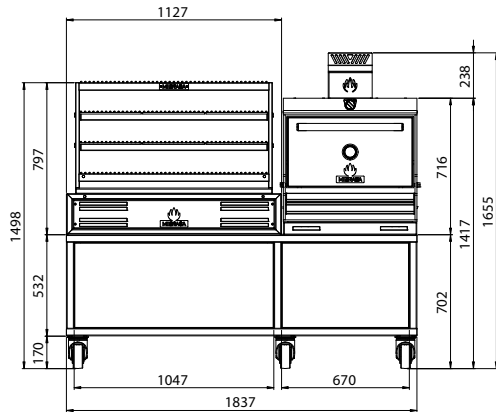

Side view

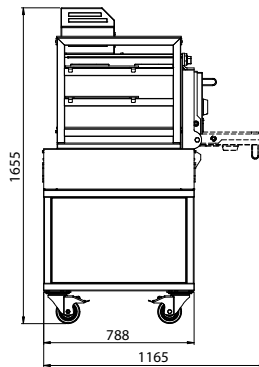

Top view

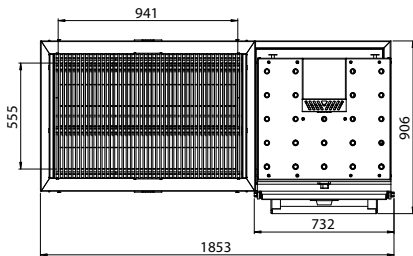

Dimensions in mm

Revit drawings available on request at mibrasa@mibrasa.com

CUSTOMIZATION

COLOR



BLACK



RED



BLUE



YELLOW



STAINLESS
STEEL

EDITION



GOLD



BLACK



COPPER



TITANIUM



SILVER



WOOD*

The Edition finishes are applied to the logos, door handle and the thermometer casing.
*Only on the door handle (logos and thermometer casing in silver)

ROBATA BEAST MIBRASA	
A	Rod grills
B	Structure
C	Adjustable grill support
D	Refractory bricks
E	Main body
F	Stand
G	Swivel casters

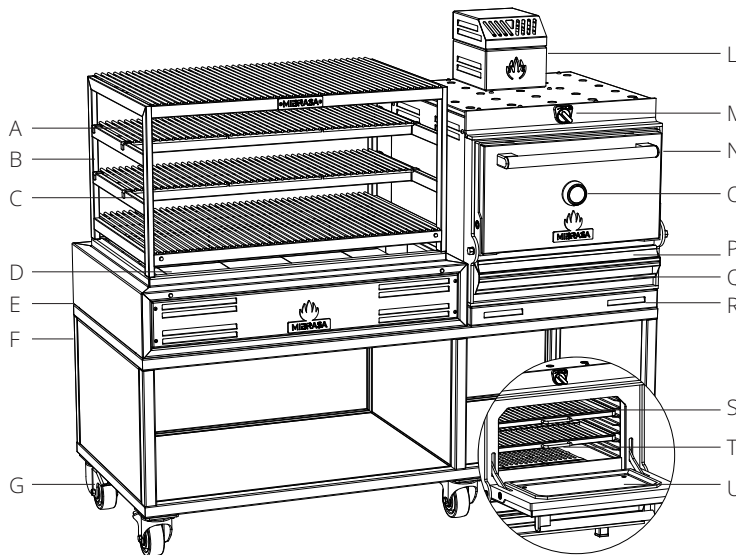

MIBRASA OVEN	
L	Firebreak-dissipating filter
M	Top damper
N	Door handle
O	Termometer
P	Removable grease collector
Q	Lower damper/ash collector
R	Trim base worktop
S	Grills
T	Charcoal grids
U	Door

SAFETY STANDARDS AND INSTALLATION GUIDELINES

Clearances to construction/other appliances from the DUO	76 mm
Clearances of flammable materials from the DUO	300 mm
Clearance of workspace from front of the DUO	1100 mm

Specifications and design are subject to change without notice.